

FICHE D'HOMOLOGATION HOMOLOGATION FORM

311/M/09



COMMISSION INTERNATIONALE DE KARTING - FIA



MOTEUR / ENGINE

ICAJ

Constructeur	<i>Manufacturer</i>	MAXTER S.R.L.
Marque	<i>Make</i>	MAXTER
Modèle	<i>Model</i>	MX-A
Type d'admission	<i>Inlet type</i>	PISTON PORT
Durée de l'homologation	<i>Validity of the homologation</i>	9 ans / 9 years
Nombre de pages	<i>Number of pages</i>	9

Cette fiche d'homologation reproduit descriptions, illustrations et dimensions du moteur au moment de l'homologation CIK. Le constructeur a la possibilité de les modifier seulement dans les limites fixées par le règlement CIK en vigueur.
La hauteur du moteur sur les photos doit être de 7cm minimum.

*This homologation sheet reproduces descriptions, illustrations and dimensions of the engine at the moment of the CIK homologation. The manufacturer may modify them, but only within the limits fixed by the CIK regulations in force.
The height of complete engines on all pictures must be min. 7cm.*



PHOTO DU MOTEUR COTE PIGNON
DRIVE SIDE ENGINE PICTURE



PHOTO DU MOTEUR COTE OPPOSE
OPPOSED SIDE ENGINE PICTURE

Signature et tampon de l'ASN
Signature and stamp of the ASN

Signature et tampon de la CIK
Signature and stamp of the CIK



Glauco



[Signature]

INFORMATIONS TECHNIQUES		TECHNICAL INFORMATION	
A	CARACTERISTIQUES	A	CARACTERISTICS
			Tolérances
Volume du cylindre	<i>Cylinder volume</i>	99.25 CM3	< 100 cc
Alésage d'origine	<i>Original Bore</i>	49.95 MM	
Alésage théor. max.	<i>Theoretical max. bore</i>	50.13 MM	
Course	<i>Stroke</i>	50.65 MM	
Système de refroidissement	<i>Cooling system</i>	AIR COOLED	
Nombre de systèmes de carburation	<i>Number of carburation systems</i>	1	
Nombre de canaux de transfert, cylindre/carter	<i>Number of transfer ducts in the cylinder</i>	4 / 2	
Nombre de lumières / canaux d'échappement	<i>Number of exhaust ports / ducts</i>	2	
Forme de la chambre de combustion	<i>Shape of the combustion chamber</i>	SPHERICAL WITH SQUISH	
Longueur (entre-axe) de la bielle	<i>Length between the axes of the connecting rod</i>	100 MM	±0.1mm
Poids de la bielle	<i>Weight of the connecting rod</i>	103 GR	minimum
Poids du vilebrequin	<i>Weight of the crankshaft</i>	1.634 GR	minimum
Volume de la chambre de combustion	<i>Volume of combustion chamber</i>	4.83 CM3	minimum
Nombre de segments de piston	<i>Number of piston rings</i>		
Modifications autorisées selon Règlement Technique. Seules les dimensions et cotes qui ne peuvent pas être modifiées doivent obligatoirement figurer sur la fiche d'homologation.			
<i>Modification allowed according to Technical Regulation. Only the dimensions and readings which may not be changed must obligatorily be mentioned on the homologation form.</i>			

B	ANGLES D'OUVERTURE	B	OPENING ANGLES
De l'admission	<i>Inlet</i>	160.2°	Maximum
De l'échappement	<i>Exhaust</i>	172.2°	Maximum

C	MATERIAU	C	MATERIAL
Cylindre	<i>Cylinder</i>	AL - SI 9	
Culasse	<i>Cylinderhead</i>	AL - SI 9	
Carter	<i>Sump</i>	AL - SI 9	
Bielle	<i>Connecting rod</i>	16 N CR M 5	

DESSIN DU DEVELOPPEMENT DU CYLINDRE

DRAWING OF THE CYLINDER DEVELOPMENT

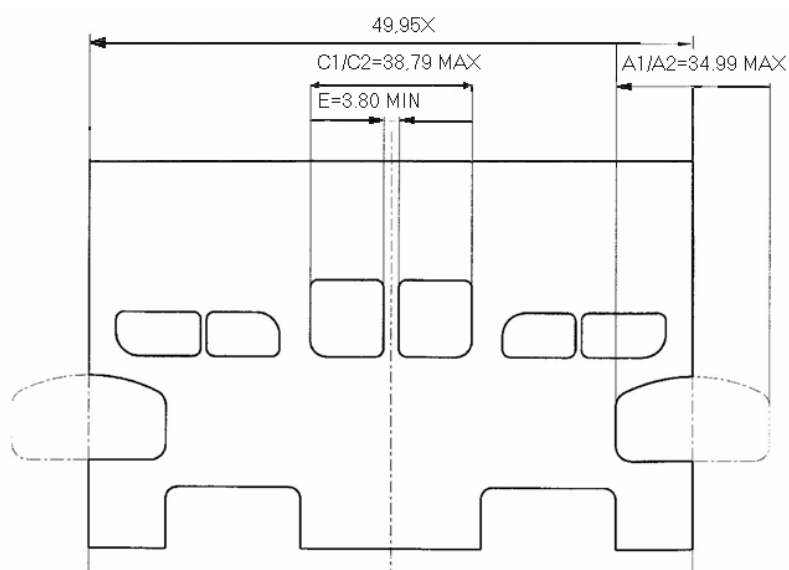

Se référer à l'exemple de calcul donné à la page 6 où D représente le diamètre théorique max.

Indiquer sur le dessin:

B_{min} = épaisseur minimum de la division entre les lumières d'admission (s'il y en a une).

$A1/A2$ = Largeur maximum de l'admission mesurée à la corde.

E_{min} = épaisseur minimum de la division entre les lumières d'échappement (s'il y en a une).

$C1/C2$ = largeur maximum de l'échappement mesurée à la corde.

Refer to the calculation model shown on page 6 where D is the original theoretical max. diameter.

Show on the drawing:

B_{min} = minimum thickness of the inlet rib (if existing).

$A1/A2$ = max. inlet width-chordal width.

E_{min} = minimum thickness of exhaust rib (if existing).

$C1/C2$ = max exhaust width-chordal width.

DESSIN DU PIED DU CYLINDRE

DRAWING OF THE CYLINDER BASE

VUE EN SECTION DU CYLINDRE

CYLINDER SECTION VIEW

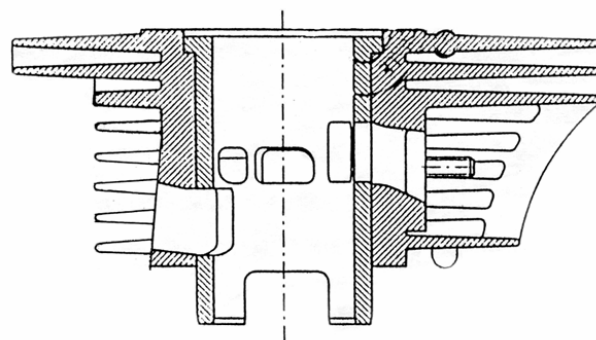
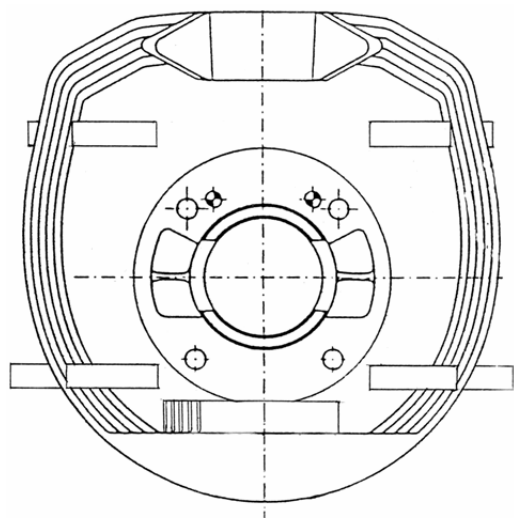

DESSIN DE LA CULASSE ET DE LA CHAMBRE
DE COMBUSTION

*DRAWING OF THE CYLINDER HEAD AND THE
COMBUSTION CHAMBER*

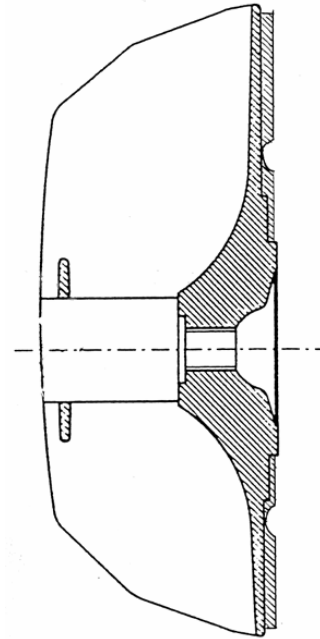
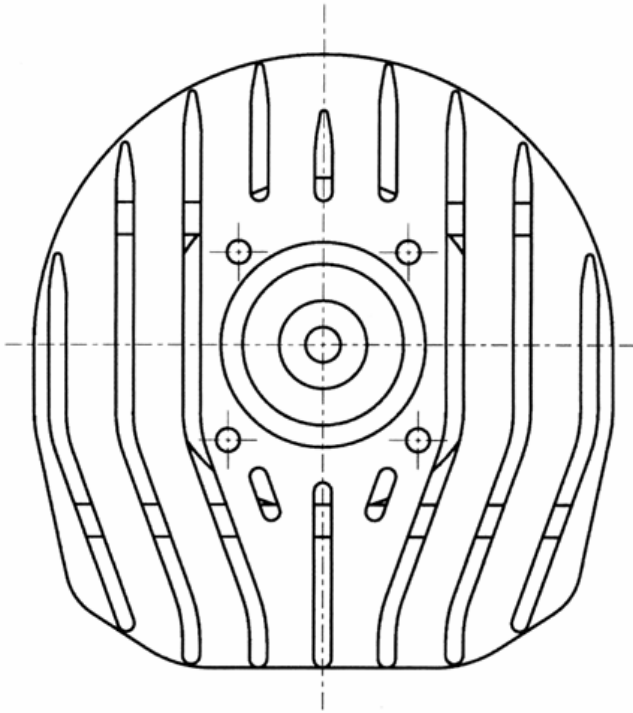

DESSIN DU
VILEBREQUIN

*DRAWING OF THE
CRANKSHAFT*

DESSIN INTERIEUR
DU CARTER

*DRAWING OF THE
INTERIOR SUMP*

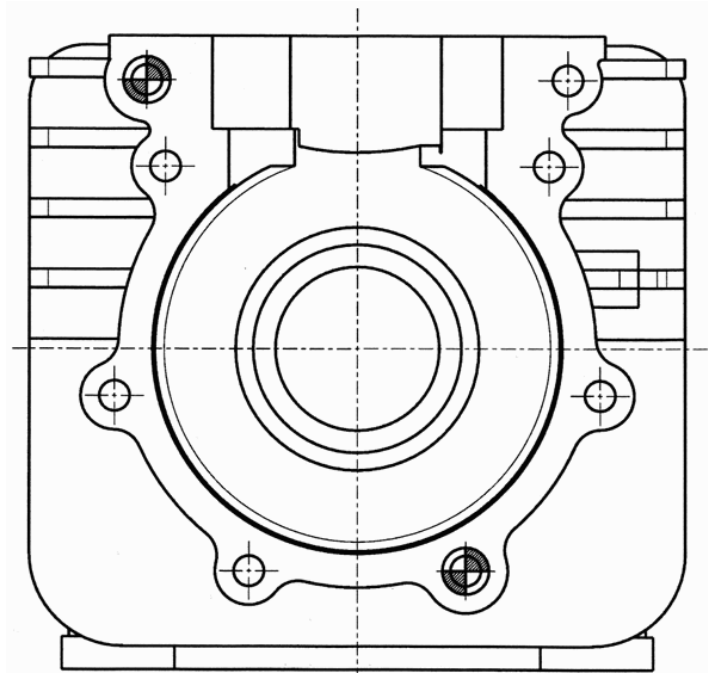
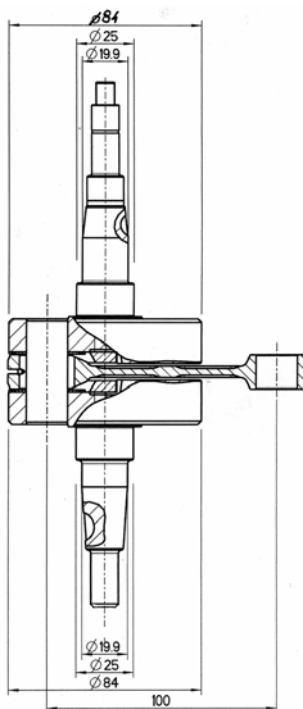





<p>PHOTO DE L'ARRIERE DU MOTEUR</p>	<p><i>PHOTO OF THE BACK OF THE ENGINE</i></p>	<p>PHOTO DE L'AVANT DU MOTEUR</p>	<p><i>PHOTO OF THE ENGINE FRONT</i></p>
			
<p>PHOTO DU MOTEUR PARTIE SUPERIEURE</p>	<p><i>PHOTO OF THE ENGINE TAKEN FROM ABOVE</i></p>	<p>PHOTO DU MOTEUR PARTIE INFERIEURE</p>	<p><i>PHOTO OF THE ENGINE TAKEN FROM BELOW</i></p>
			

PHOTO DU PIED DU CYLINDRE	<i>PHOTO OF THE BASE OF THE CYLINDER</i>	PHOTO DE LA CHAMBRE DE COMBUSTION	<i>PHOTO OF THE COMBUSTION CHAMBER</i>
			
PHOTO DU CARTER (FACE DE JOINT)	<i>PHOTO OF THE SUMP (GASKET FACE)</i>	PHOTO D'UNE PARTIE INTERIEURE DU CARTER	<i>PHOTO OF A PART OF THE SUMP'S INTERIOR</i>
			

MESURE CORDALE LUMIERE D'ADMISSION	INLET PORT CHORD WIDTH	
La largeur maximale est: FORMULE: $A1=D \times \pi \times 0,223 + B \text{ min}$	The maximum width is: FORMULA: $A2=D \times \pi \times 0,223$	
D = Diamètre théorique max. / theoretical max diameter.		
MESURE CORDALE LUMIERE D'ECHAPPEMENT	EXHAUST PORT CHORD WIDTH	
La largeur maximale est: FORMULE: $C1=D \times \pi \times 0,223 + E \text{ min}$	The maximum width is: FORMULA: $C2=D \times \pi \times 0,223$	
D = Diamètre théorique max. / theoretical max diameter.		
SCHEME B INLET PORT TIMING VS. STROKE DIAGRAMME DE LA LUMIERE D'ADMISSION COMPARE AVEC LA COURSE	SCHEME A EXHAUST PORT TIMING VS. STROKE DIAGRAMME DE LA LUMIERE D'ECHAPPEMENT COMPARE AVEC LA COURSE	LEGENDA: <i>a</i> = Max angle d'ouverture / Max opening angle <i>C</i> = Course / Stroke
$a = 2 \times [82 - (C - 46) \times 0,4]$ exemple: $C = 51 \ll a = 160^\circ$	$a = 2 \times \{ 180 - [92 + (C - 46) \times 0,4] \}$ exemple: $C = 51 \ll a = 172^\circ$	

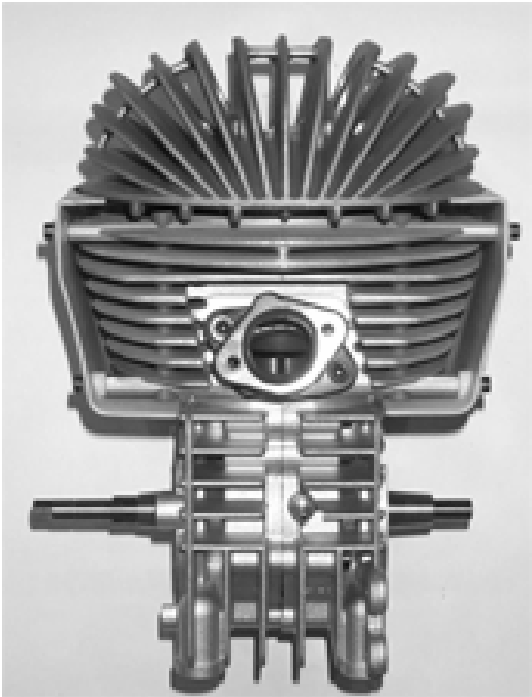
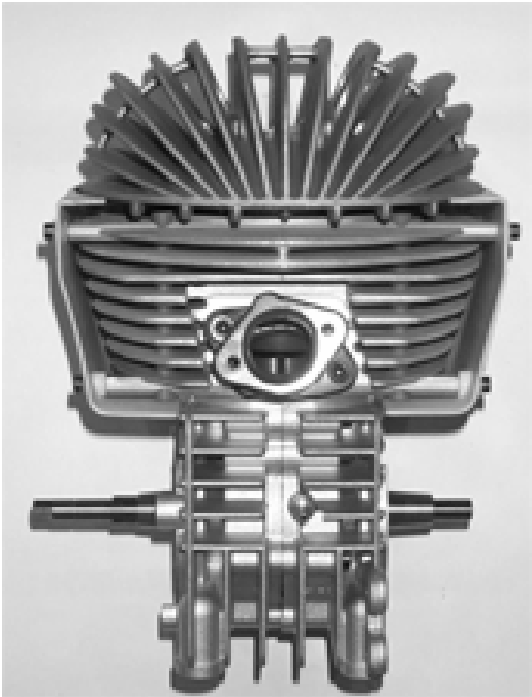
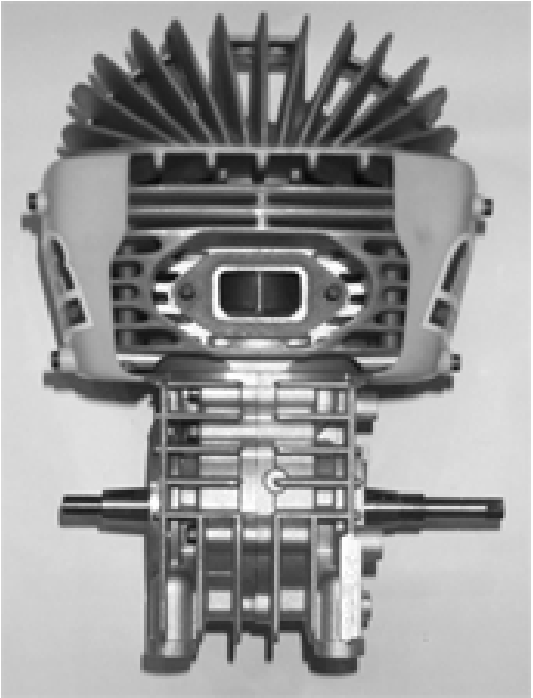
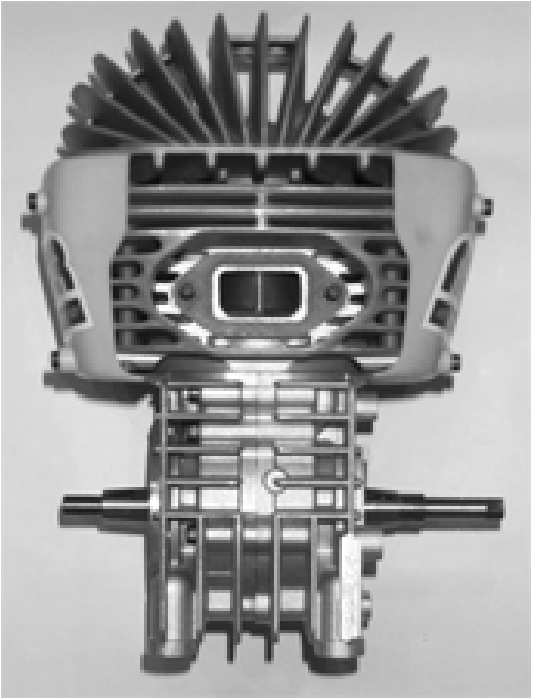
DESSIN DU SILENCIEUX ET SES ELEMENTS

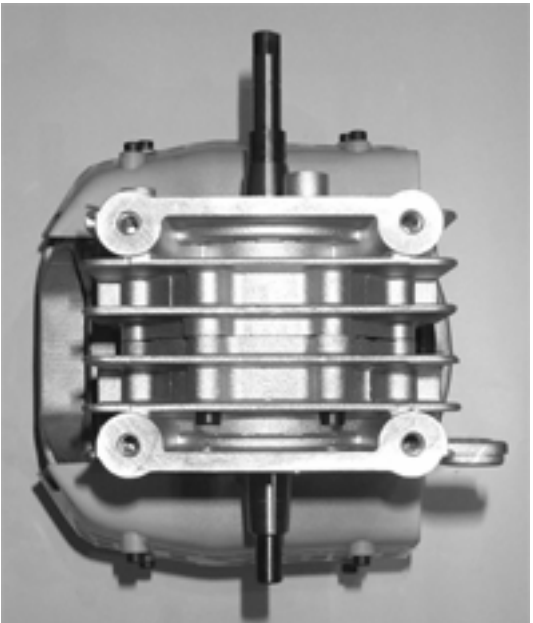
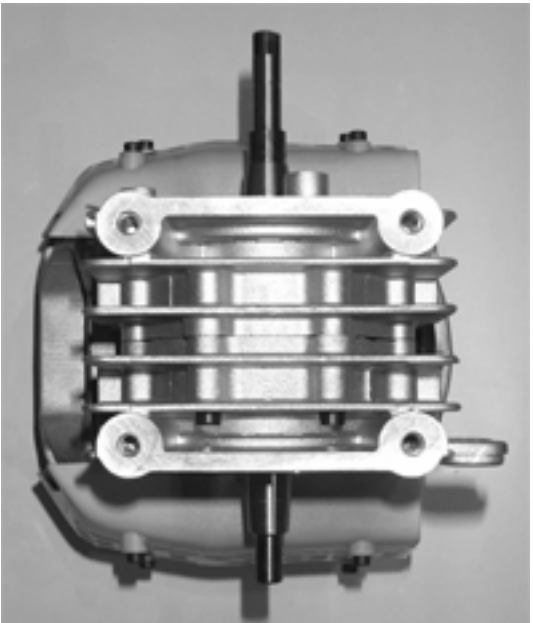
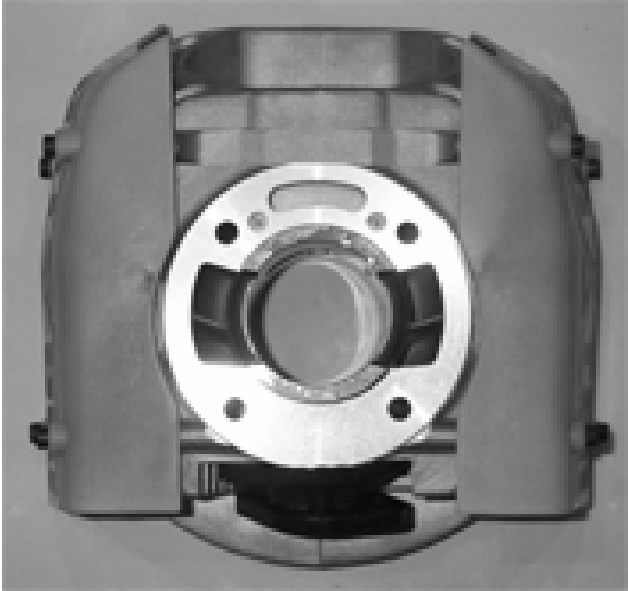
DRAWING OF THE SILENCER AND COMPONENTS

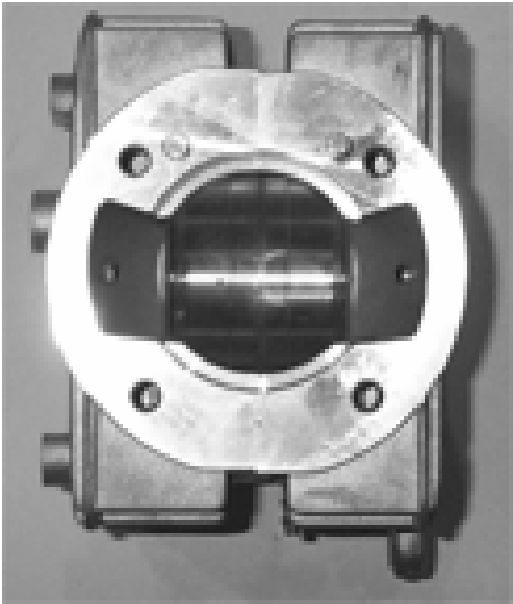
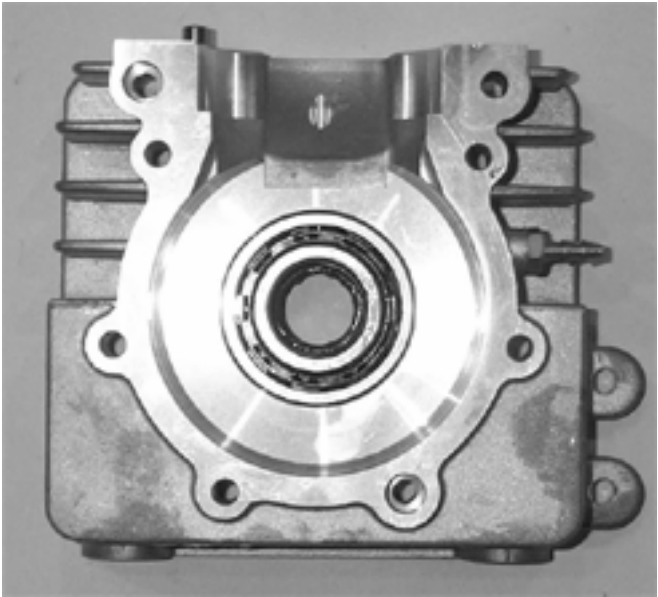
Epaisseur minimum de la paroi du pot-silencieux 0,8mm / Thickness minimum of the wall of the silencer 0,8mm.

Poids de l'échappement, minimum 1.400 Kg / Minimum weight of the silencer 1.400 Kg.

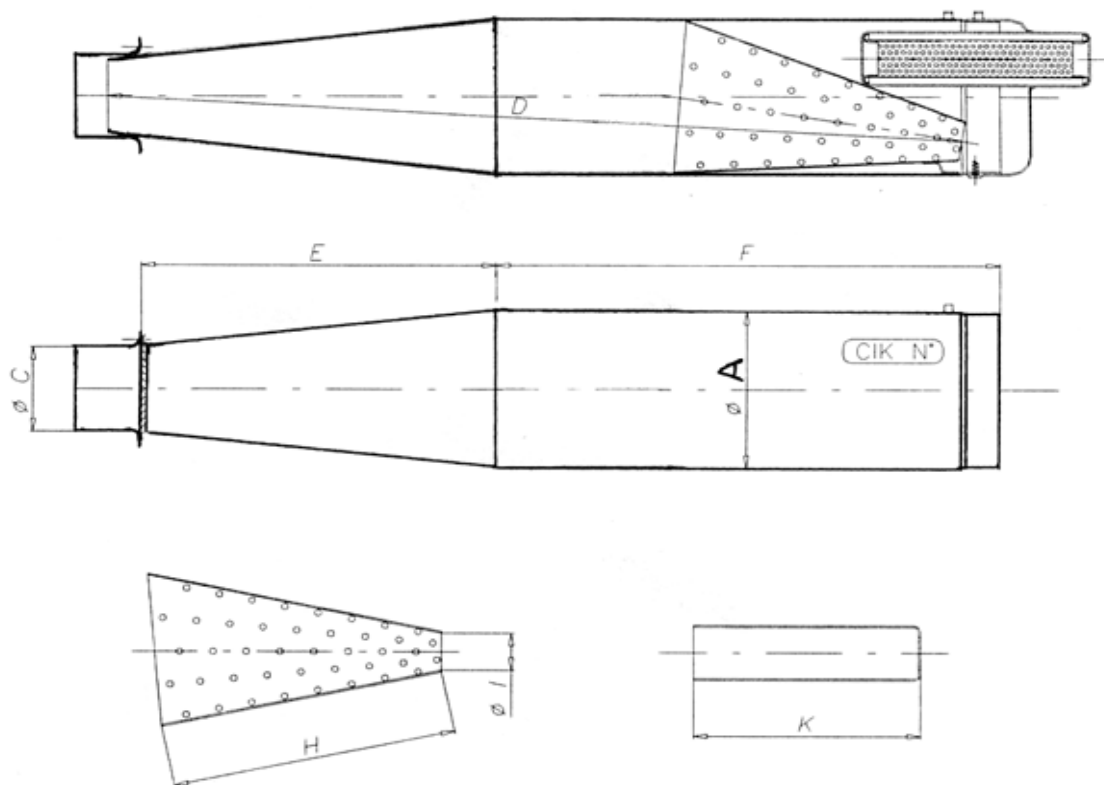

Les parties terminales du silencieux doivent présenter deux paires d'anneaux soudés (une en haut et une en bas), pour retenir le sceau en plomb, fixé par l'Organisateur pour que le silencieux ne puisse pas être ouvert pendant la compétition.

The end of the silencer must have two pairs of lugs (one pair top and one pair bottom) for the fixing of seals by the Organizer so that the silencer may be opened during the Competition

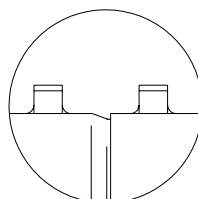
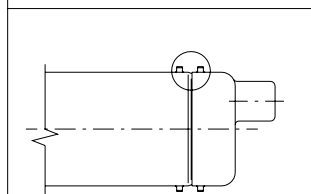
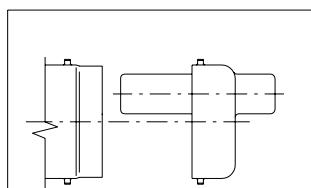

Cotes / Readings:

A: **100 Øext.**F: **315**

B:.

G: _____

C: **54 Øext.**H: **172**D: **475**I: **22**E: **170**K: **130**

TOLERANCES

Cotes Brute / Rough-cast dimension
 Jusque - up to 25mm → ±1mm
 De à - from to 25-60mm → ±1,5mm
 Plus que - more than 60mm → ±3mm

POSITION DU CARBURATEUR

CARBURETOR LOCATION

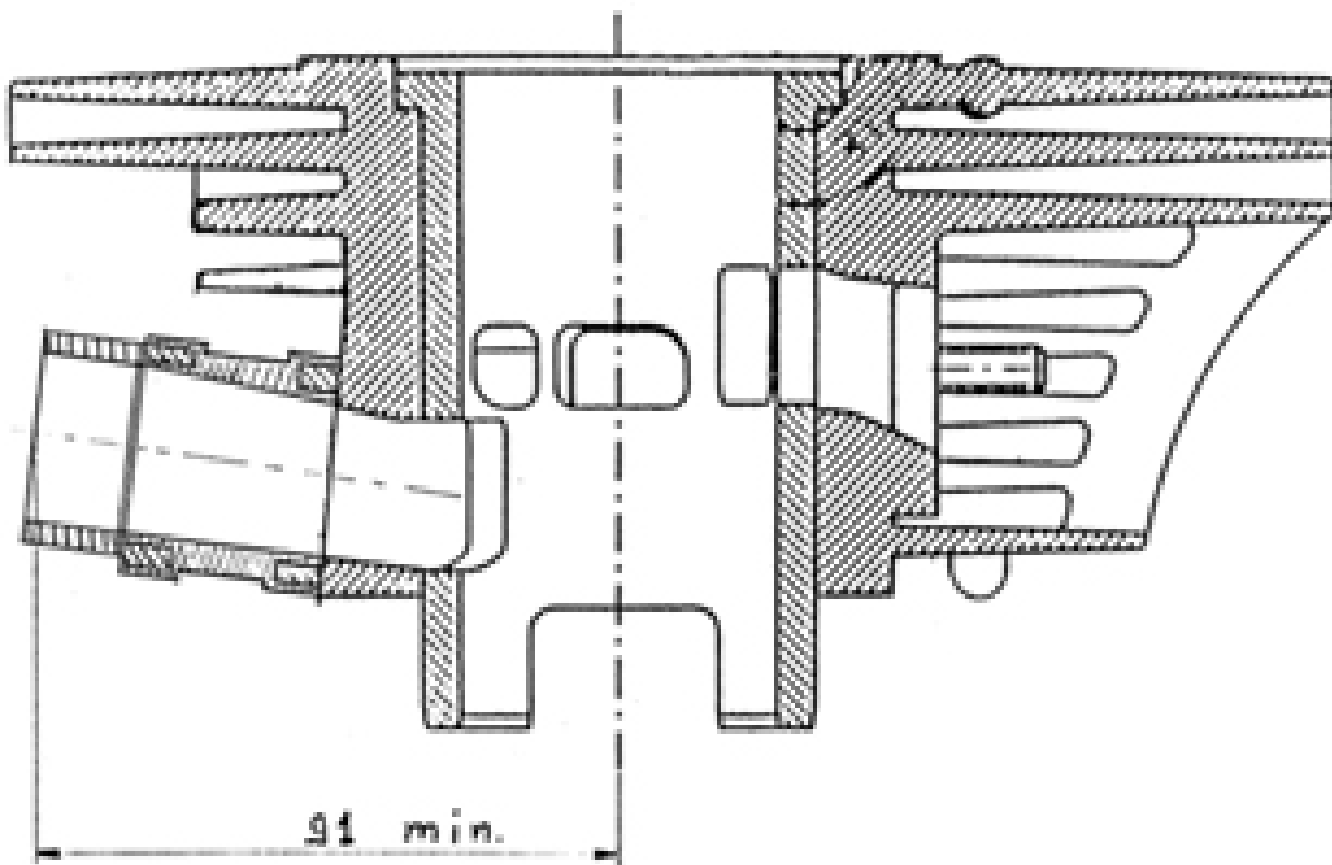

La distance de 91mm de l'axe du cylindre peut comprendre une éventuelle entretoise placée avant le carburateur.

91mm distance from the cylinder center line may include an eventual spacer located before the carburetor.