

FICHE D'HOMOLOGATION HOMOLOGATION FORM



COMMISSION INTERNATIONALE DE KARTING - FIA



MOTEUR / ENGINE ICA-J

Constructeur	<i>Manufacturer</i>	SONIK S.R.L.
Marque	<i>Make</i>	SONIK
Modèle	<i>Model</i>	PX 3
Type d'admission	<i>Inlet type</i>	PISTON PORT
Durée de l'homologation	<i>Validity of the homologation</i>	6 ans / 6 years
Nombre de pages	<i>Number of pages</i>	9

La présente Fiche d'Homologation reproduit descriptions, illustrations et dimensions du moteur au moment de l'homologation CIK-FIA. Le Constructeur a la possibilité de les modifier seulement dans les limites fixées par le règlement CIK-FIA en vigueur. La hauteur du moteur complet sur les photos doit être de 7cm minimum.

This Homologation Form reproduces descriptions, illustrations and dimensions of the engine at the moment of the CIK-FIA homologation. The Manufacturer may modify them, but only within the limits fixed by the CIK-FIA regulations in force. The height of complete engines on all photos must be minimum 7cm.



PHOTO DU MOTEUR CÔTÉ PIGNON
PHOTO OF DRIVE SIDE OF ENGINE



PHOTO DU MOTEUR CÔTÉ OPPOSÉ
PHOTO OF OPPOSITE SIDE OF ENGINE

Signature et tampon de l'ASN
Signature and stamp of the ASN

Signature et tampon de la CIK-FIA
Signature and stamp of the CIK-FIA



Glauco



[Signature]

INFORMATIONS TECHNIQUES		TECHNICAL INFORMATION	
A	CARACTÉRISTIQUES	A	CHARACTERISTICS
			Tolérances
Volume du cylindre	<i>Volume of cylinder</i>	99.15 CM3	<100 cm³
Alésage d'origine	<i>Original bore</i>	50.00 MM	
Alésage théorique maximum	<i>Theoretical maximum bore</i>	50.21 MM	
Course	<i>Stroke</i>	50.50 MM	
Système de refroidissement	<i>Cooling system</i>	AIR	
Nombre de systèmes de carburation	<i>Number of carburation systems</i>	1	
Nombre de canaux de transfert, cylindre/carter	<i>Number of transfer ducts, cylinder/sump</i>	4	
Nombre de lumières / canaux d'échappement	<i>Number of exhaust ports / ducts</i>	2	
Forme de la chambre de combustion	<i>Shape of the combustion chamber</i>	SPHERICAL OR TRUNCATED CONE	
Longueur (entre-axe) de la bielle	<i>Length between the axes of the connecting rod</i>	100 MM	±0.1mm
Poids de la bielle	<i>Weight of the connecting rod</i>	95 GR	minimum
Poids du vilebrequin	<i>Weight of the crankshaft</i>	1500 GR	minimum
Volume de la chambre de combustion	<i>Volume of combustion chamber</i>	12 CM3	minimum
Modifications autorisées selon le Règlement Technique. Seules les dimensions et cotes qui ne peuvent pas être modifiées doivent figurer sur la Fiche d'Homologation.			
<i>Modification allowed according to the Technical Regulations. Only the dimensions and readings which may not be changed must be mentioned on the Homologation Form.</i>			

B	ANGLES D'OUVERTURE	B	OPENING ANGLES
De l'admission	<i>Inlet</i>	160.4 °	Maximum
De l'échappement	<i>Exhaust</i>	172.4 °	Maximum

C	MATÉRIAU	C	MATERIAL
Cylindre	<i>Cylinder</i>	AL-SI	
Culasse	<i>Cylinder head</i>	AL-SI	
Carter	<i>Sump</i>	AL-SI	
Bielle	<i>Connecting rod</i>	STEEL ALLOY CR-MO	

DESSIN DU DÉVELOPPEMENT DU CYLINDRE

DRAWING OF THE CYLINDER DEVELOPMENT

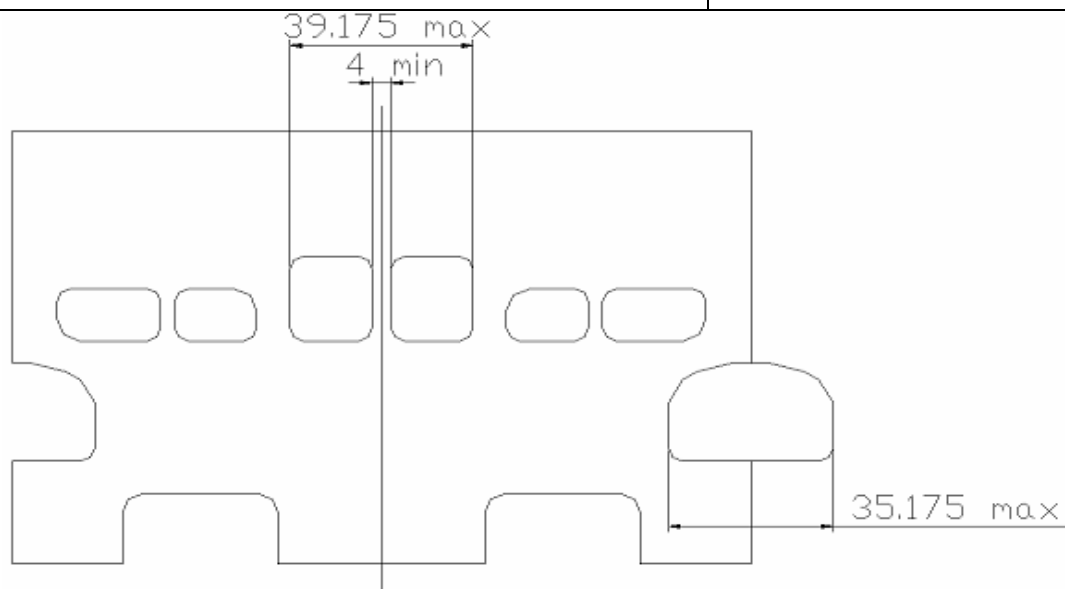

Se référer à l'exemple de calcul donné à la page 6 où D représente le diamètre théorique maximum.
Indiquer sur le dessin :
 B_{min} = épaisseur minimum de la division entre les lumières d'admission (s'il y en a une).
 $A1/A2$ = Largeur maximum de l'admission mesurée à la corde.
 E_{min} = épaisseur minimum de la division entre les lumières d'échappement (s'il y en a une).
 $C1/C2$ = largeur maximum de l'échappement mesurée à la corde.

Refer to the calculation model shown on page 6 where D is the original theoretical maximum diameter.

Show on the drawing:

B_{min} = minimum thickness of the inlet rib (if existing).
 $A1/A2$ = maximum inlet width measured at the chord.
 E_{min} = minimum thickness of exhaust rib (if existing).
 $C1/C2$ = maximum exhaust width measured at the chord.

DESSIN DU PIED DU CYLINDRE

DRAWING OF THE CYLINDER BASE

VUE EN SECTION DU CYLINDRE

SECTION VIEW OF CYLINDER

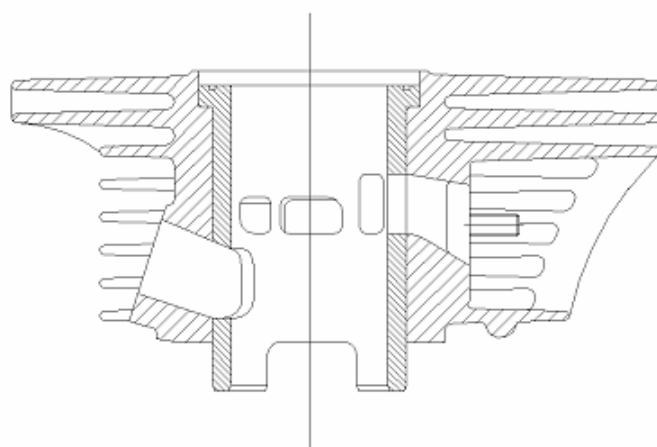
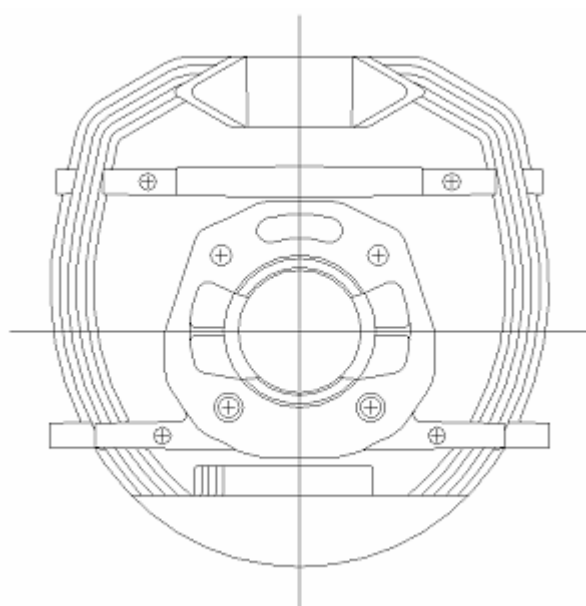

DESSIN DE LA CULASSE ET DE LA CHAMBRE
DE COMBUSTION

*DRAWING OF THE CYLINDER HEAD AND THE
COMBUSTION CHAMBER*

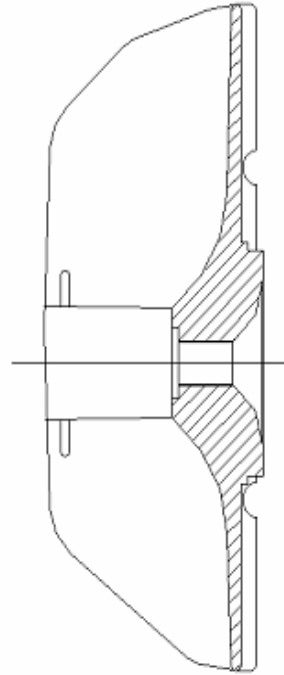
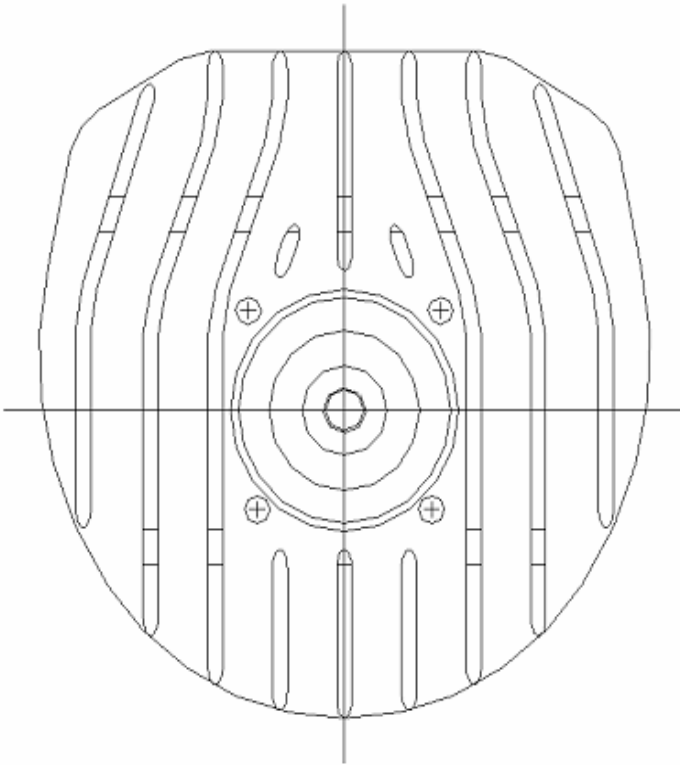

DESSIN DU
VILEBREQUIN

*DRAWING OF THE
CRANKSHAFT*

DESSIN INTÉRIEUR
DU CARTER

*DRAWING OF THE
INSIDE OF SUMP*

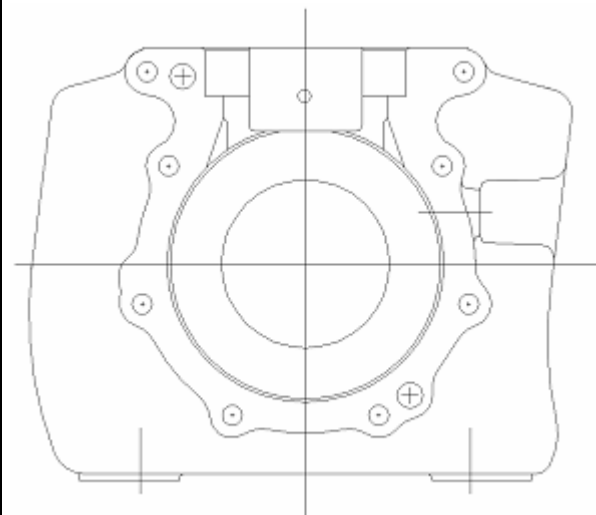
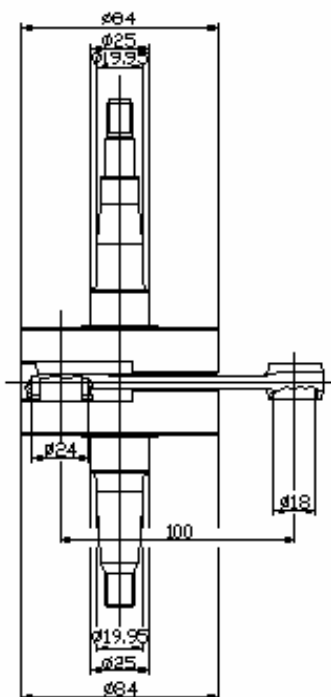

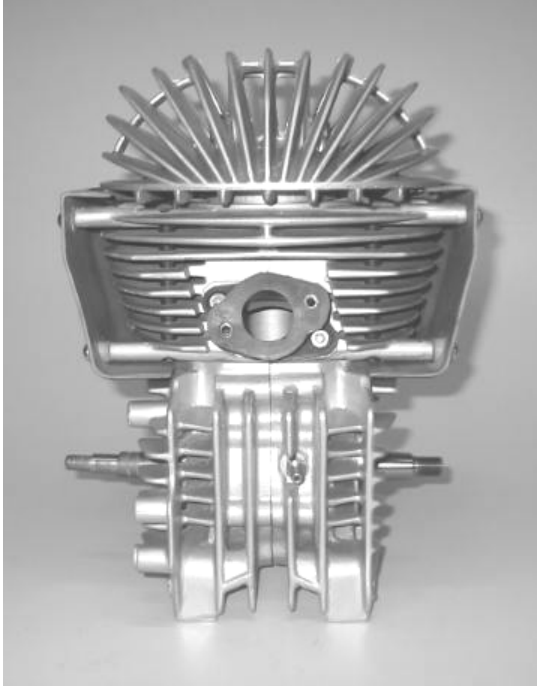

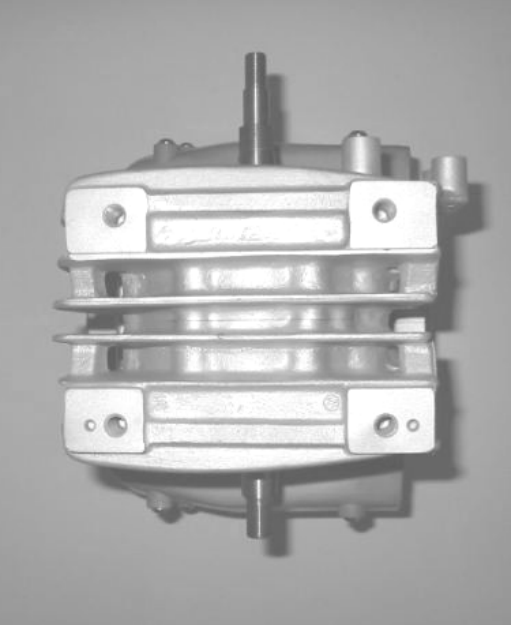
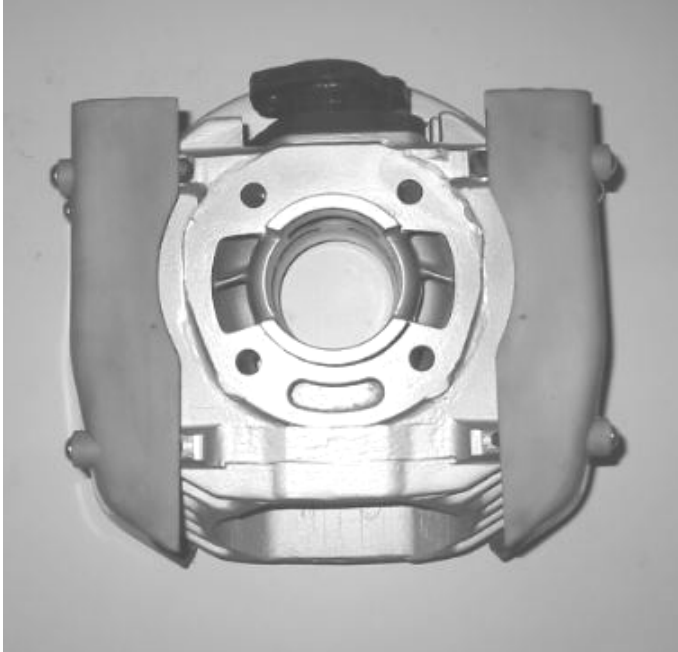
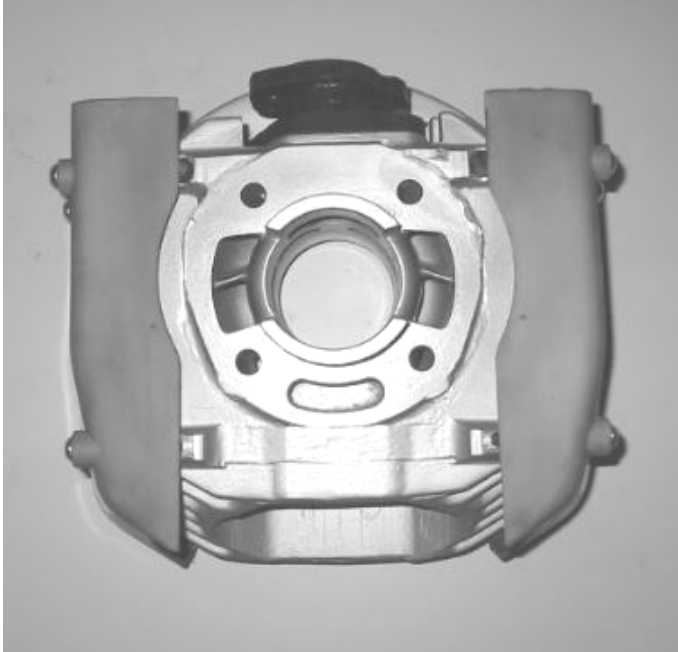

PHOTO DE L'ARRIÈRE DU MOTEUR	<i>PHOTO OF THE BACK OF THE ENGINE</i>	PHOTO DE L'AVANT DU MOTEUR	<i>PHOTO OF THE FRONT OF THE ENGINE</i>
			
PHOTO DU MOTEUR PARTIE SUPÉRIEURE	<i>PHOTO OF THE ENGINE TAKEN FROM ABOVE</i>	PHOTO DU MOTEUR PARTIE INFÉRIEURE	<i>PHOTO OF THE ENGINE TAKEN FROM BELOW</i>
			

PHOTO DU PIED DU CYLINDRE	PHOTO OF THE BASE OF THE CYLINDER	PHOTO DE LA CHAMBRE DE COMBUSTION	PHOTO OF THE COMBUSTION CHAMBER
			
PHOTO DU CARTER (CÔTÉ JOINT)	PHOTO OF THE SUMP (GASKET SIDE)	PHOTO D'UNE PARTIE INTÉRIEURE DU CARTER	PHOTO OF A PART OF THE INSIDE OF SUMP CARTER
			

MESURE CORDALE LUMIÈRE D'ADMISSION	INLET PORT CHORD WIDTH	
La largeur maximale est : FORMULE : $A1 = D \times \pi \times 0,223 + B \text{ min}$	The maximum width is: FORMULE : $A2 = D \times \pi \times 0.223 = 35.175$	
D = Diamètre théorique maximum / theoretical maximum diameter.		
		
MESURE CORDALE LUMIÈRE D'ÉCHAPPEMENT	EXHAUST PORT CHORD WIDTH	
La largeur maximale est : FORMULE : $C1 = D \times \pi \times 0,223 + E \text{ min} = 39.175$	The maximum width is: FORMULE : $C2 = D \times \pi \times 0.223$	
D = Diamètre théorique maximum / theoretical maximum diameter.		
		
DIAGRAMME B DIAGRAM OF INLET PORT TIMING VS. STROKE DIAGRAMME DE LA LUMIÈRE D'ADMISSION COMPARÉE AVEC LA COURSE	DIAGRAMME A DIAGRAM OF EXHAUST PORT TIMING VS. STROKE DIAGRAMME DE LA LUMIÈRE D'ÉCHAPPEMENT COMPARÉE AVEC LA COURSE	
		LÉGENDE / KEY: <i>a</i> = Angle maximum d'ouverture / Maximum opening angle <i>C</i> = Course / Stroke
$a = 2 \times [82 - (C - 46) \times 0,4] = 160.4^\circ$ exemple : $C = 51 \ll a = 160^\circ$	$a = 2 \times \{ 180 - [92 + (C - 46) \times 0,4] \} = 172.4^\circ$ exemple : $C = 51 \ll a = 172^\circ$	

DESSIN DU SILENCIEUX
ET DE SES ÉLÉMENTSDRAWING OF THE SILENCER
AND OF ITS COMPONENTS

Épaisseur minimum de la paroi du pot-silencieux : 0,8mm / Minimum wall thickness of the exhaust silencer: 0.8mm.

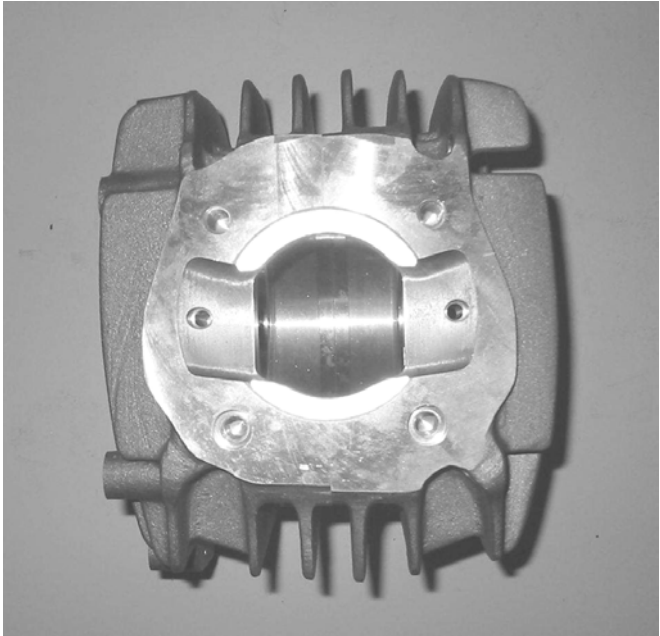
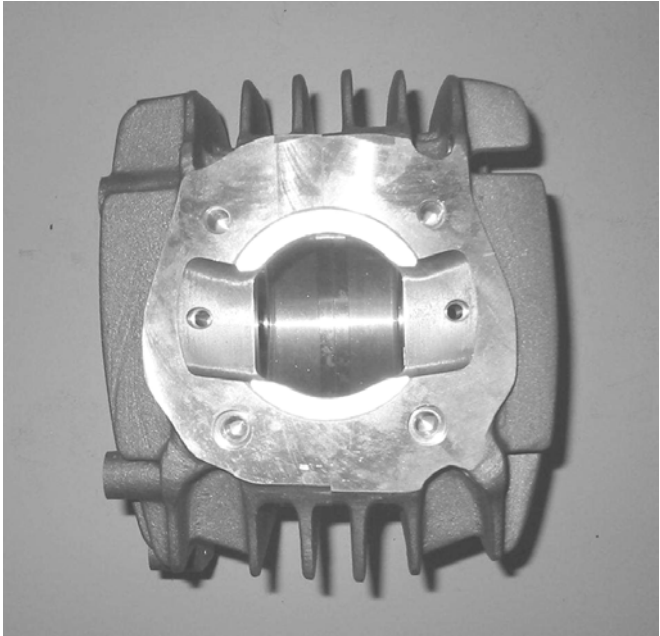
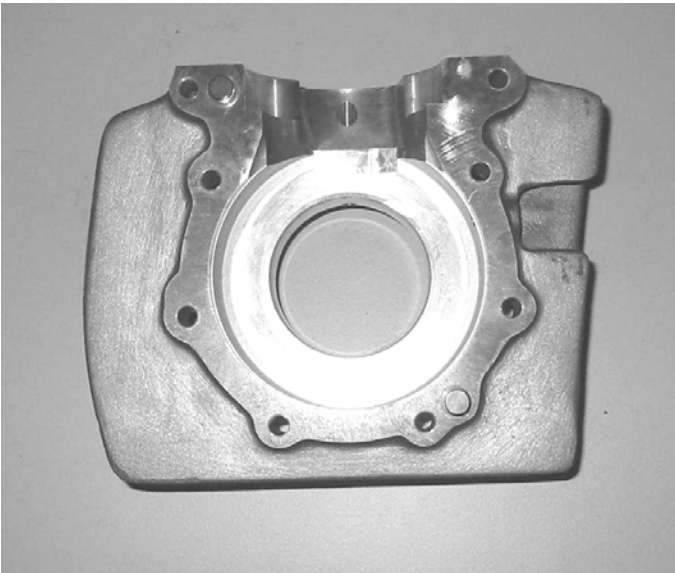
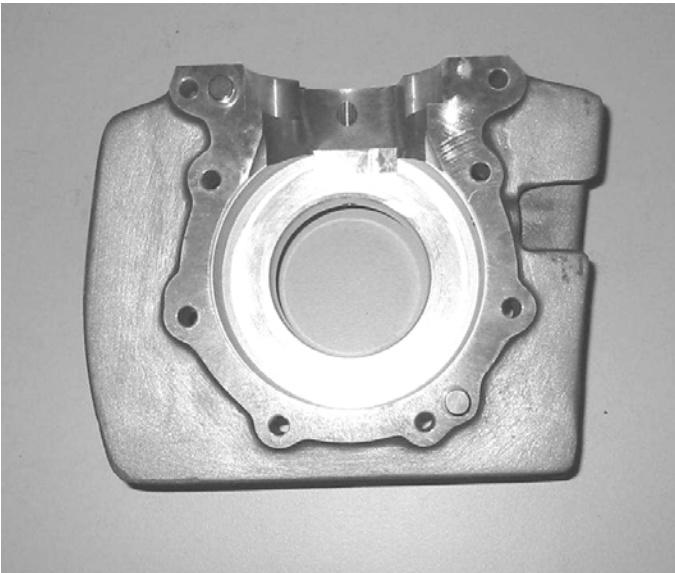
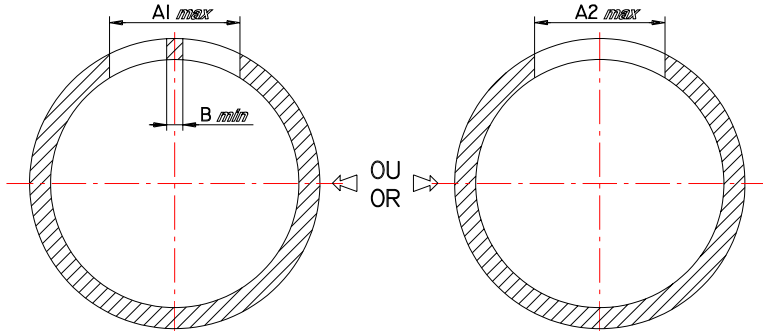
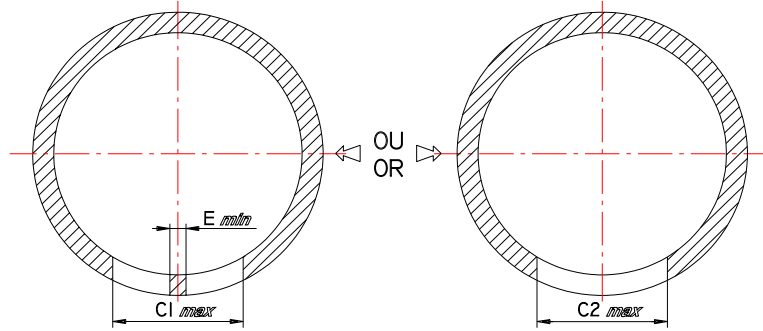
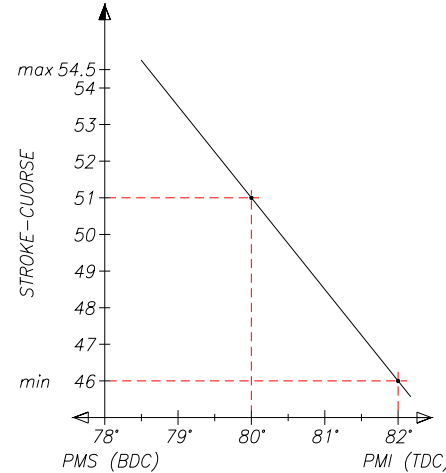
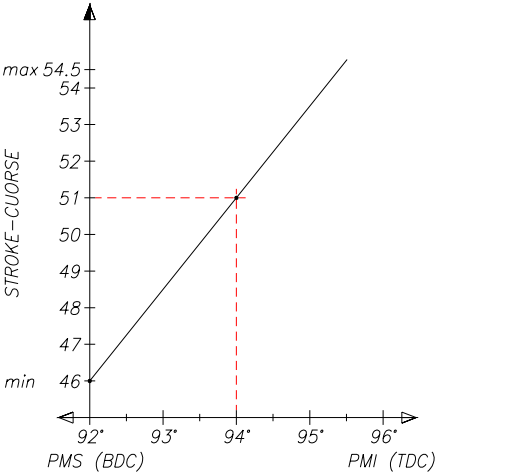
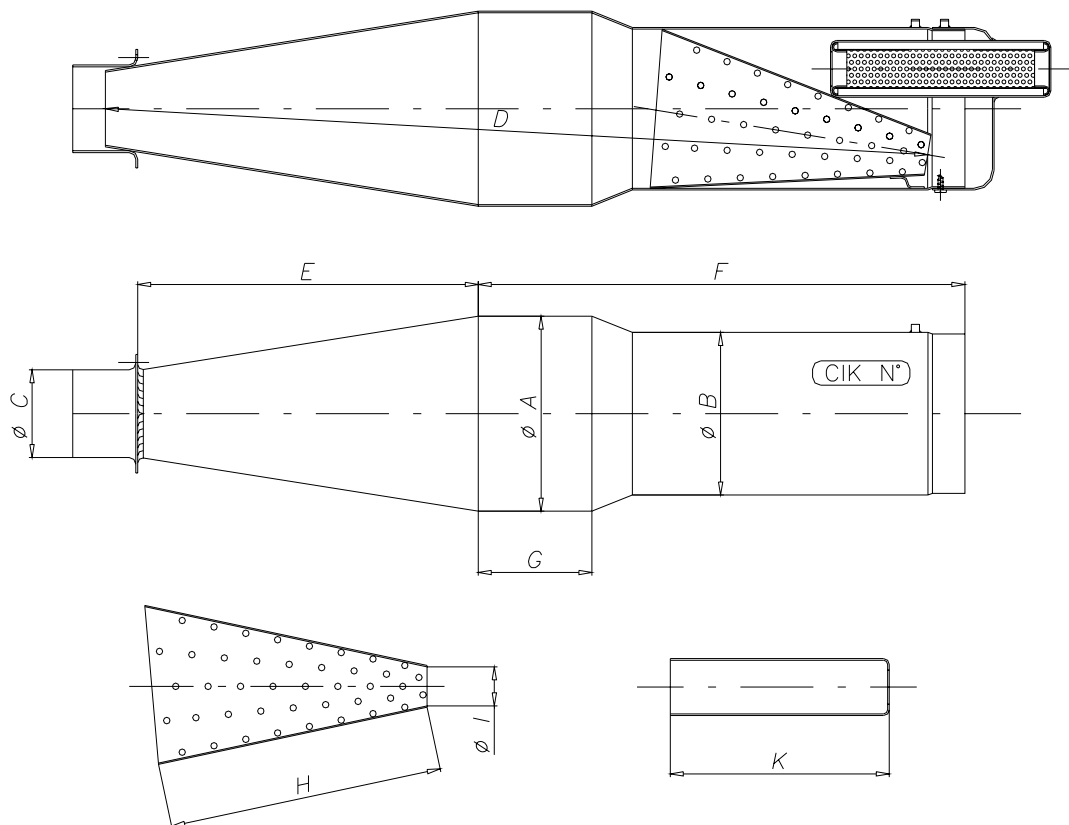
Poids minimum de l'échappement 1.5 Kg / Minimum weight of the exhaust 1.5 Kg.

Les parties terminales du silencieux doivent présenter deux paires d'anneaux soudés (une en haut et une en bas) pour retenir le plomb fixé par l'Organisateur afin que le silencieux ne puisse pas être ouvert pendant la compétition.

The end parts of the silencer must have two soldered pairs of lugs (one pair at the top and one pair at the bottom) for the fixing of seals by the Organiser so that the silencer may be opened during the competition

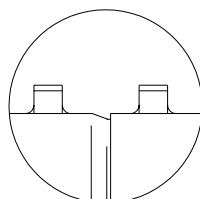
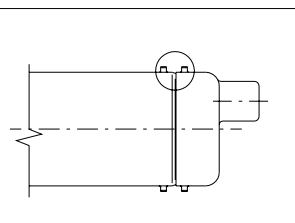
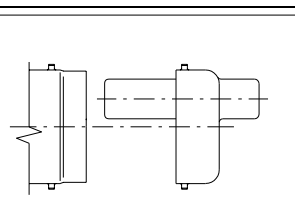

Cotes / Readings:

A: 107.5 \varnothing ext.F: 318B: 100 \varnothing ext.G: 100C: 54 \varnothing ext.H: 170D: 479I: 21E: 178.5K: 130

TOLÉRANCES

Cotes brutes / Rough dimensions

Jusque - up to 25mm $\rightarrow \pm 1$ mmDe à - from to 25-60mm $\rightarrow \pm 1,5$ mmPlus que - more than 60mm $\rightarrow \pm 3$ mm

POSITION DU CARBURATEUR

CARBURETTOR LOCATION

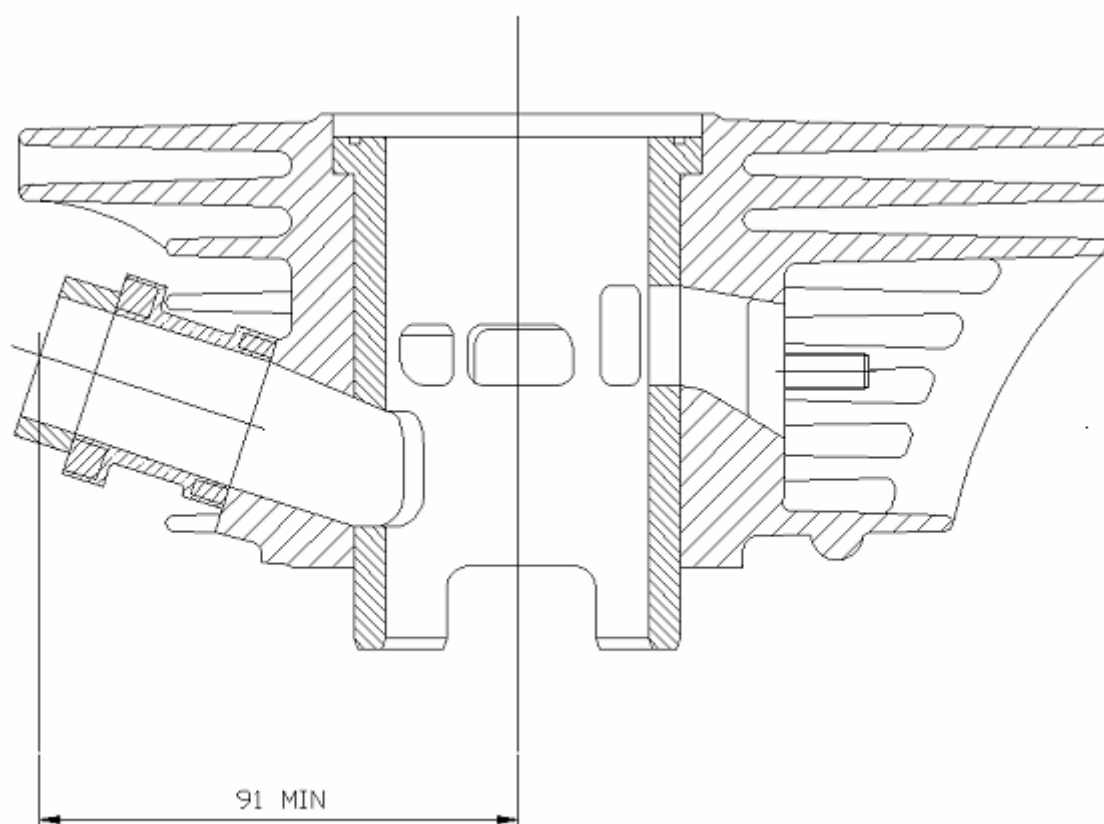

La distance de 91mm de l'axe du cylindre peut comprendre une éventuelle entretoise placée avant le carburateur.

The 91mm distance from the cylinder center line may include a possible spacer located before the carburettor.