

FICHE D'HOMOLOGATION HOMOLOGATION FORM



COMMISSION INTERNATIONALE DE KARTING - FIA



MOTEUR / ENGINE ICA

Constructeur	<i>Manufacturer</i>	IAME S.P.A. – ZINGONIA (I)
Marque	<i>Make</i>	PARILLA
Modèle	<i>Model</i>	REEDJET - MAXI
Type d'admission	<i>Inlet type</i>	CLAPETS
Durée de l'homologation	<i>Validity of the homologation</i>	9 ans / 9 years
Nombre de pages	<i>Number of pages</i>	7

La présente Fiche d'Homologation reproduit descriptions, illustrations et dimensions du moteur au moment de l'homologation CIK-FIA. Le Constructeur a la possibilité de les modifier seulement dans les limites fixées par le règlement CIK-FIA en vigueur. La hauteur du moteur complet sur les photos doit être de 7cm minimum.

This Homologation Form reproduces descriptions, illustrations and dimensions of the engine at the moment of the CIK homologation. The Manufacturer may modify them, but only within the limits fixed by the CIK-FIA regulations in force. The height of complete engines on all photos must be minimum 7cm.

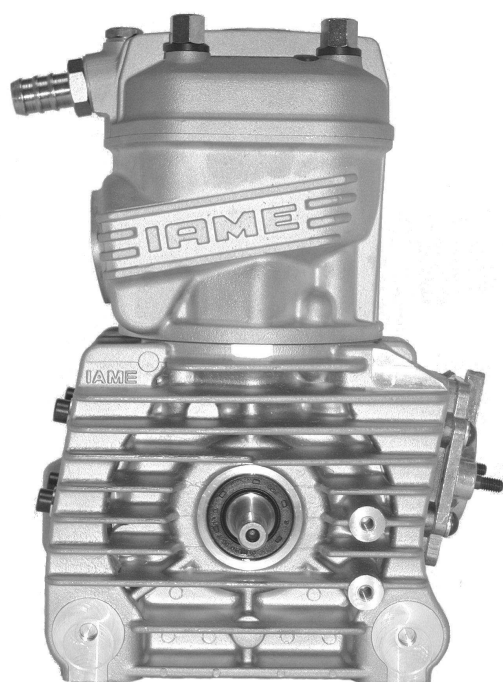

PHOTO DU MOTEUR CÔTÉ PIGNON
PHOTO OF DRIVE SIDE OF ENGINE

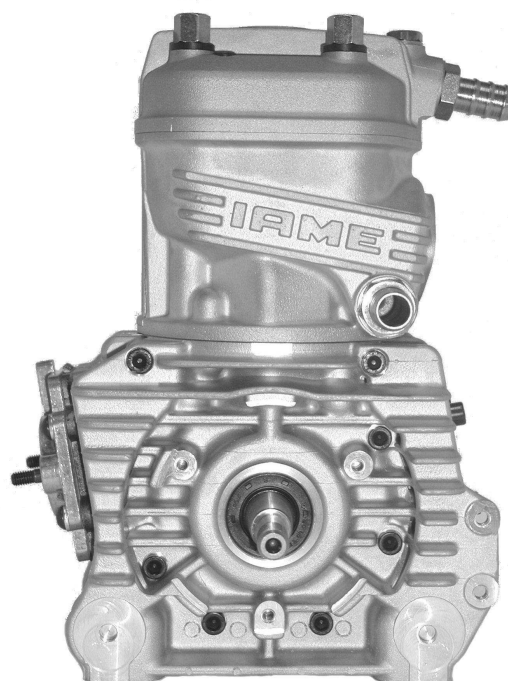

PHOTO DU MOTEUR CÔTÉ OPPOSÉ
PHOTO OF OPPOSITE SIDE OF ENGINE

Signature et tampon de l'ASN
Signature and stamp of the ASN

Signature et tampon de la CIK-FIA
Signature and stamp of the CIK-FIA



Glauco



[Signature]

INFORMATIONS TECHNIQUES		TECHNICAL INFORMATION	
A	CARACTÉRISTIQUES	A	CHARACTERISTICS
			Tolérances
Volume du cylindre	<i>Volume of cylinder</i>	<u>99.31 CM3</u>	< 100cm³
Alésage d'origine	<i>Original Bore</i>	<u>49.94 MM</u>	
Alésage théorique maximum	<i>Theoretical maximum bore</i>	<u>50.11 MM</u>	
Course	<i>Stroke</i>	<u>50.7 MM</u>	
Système de refroidissement	<i>Cooling system</i>	<u>WATER COOLED</u>	
Nombre de systèmes de carburation	<i>Number of carburation systems</i>	<u>1</u>	
Nombre de canaux de transfert, cylindre/carter	<i>Number of transfer ducts, cylinder/sump</i>	<u>3 / 3</u>	
Nombre de lumières / canaux d'échappement	<i>Number of exhaust ports / ducts</i>	<u>3</u>	
Forme de la chambre de combustion	<i>Shape of the combustion chamber</i>	<u>CALOTTE SPHERIQUE</u>	
Longueur (entre-axe) de la bielle	<i>Length between the axes of the connecting rod</i>	<u>100 MM</u>	±0.1mm
Poids de la bielle	<i>Weight of the connecting rod</i>	<u>103 GR</u>	minimum
Poids du vilebrequin	<i>Weight of the crankshaft</i>	<u>1584 GR</u>	minimum
Volume de la chambre de combustion	<i>Volume of combustion chamber</i>	<u>5.5 CM3</u>	minimum
Nombre de segments de piston	<i>Number of piston rings</i>		
Modifications autorisées selon le Règlement Technique. Seules les dimensions et cotes qui ne peuvent pas être modifiées doivent figurer sur la Fiche d'Homologation.			
<i>Modification allowed according to the Technical Regulations. Only the dimensions and readings which may not be changed must be mentioned on the Homologation Form.</i>			

B	ANGLES D'OUVERTURE	B	OPENING ANGLES
De l'échappement	<i>Exhaust</i>	<u>177°</u>	Maximum

C	MATÉRIAU	C	MATERIAL
Cylindre	<i>Cylinder</i>	<u>AL - SI (GALS I 9) / FONTE</u>	
Culasse	<i>Cylinder head</i>	<u>AL - SI (GALS I 9)</u>	
Carter	<i>Sump</i>	<u>AL - SI (GALS I 9)</u>	
Bielle	<i>Connecting rod</i>	<u>ACIER CR - MO</u>	

DESSIN DU DÉVELOPPEMENT DU CYLINDRE

DRAWING OF THE CYLINDER DEVELOPMENT

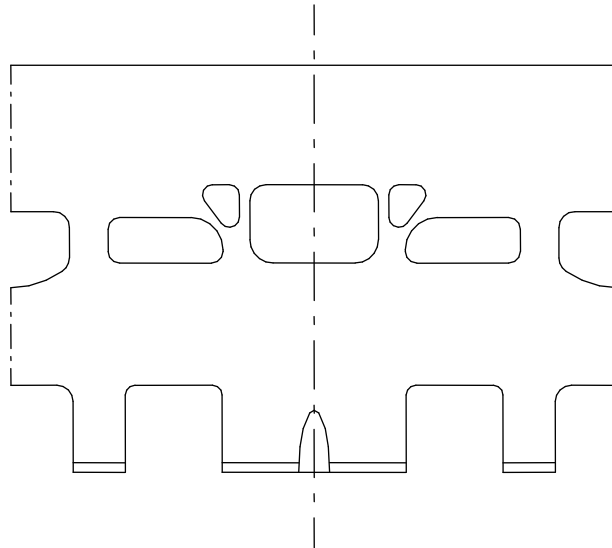
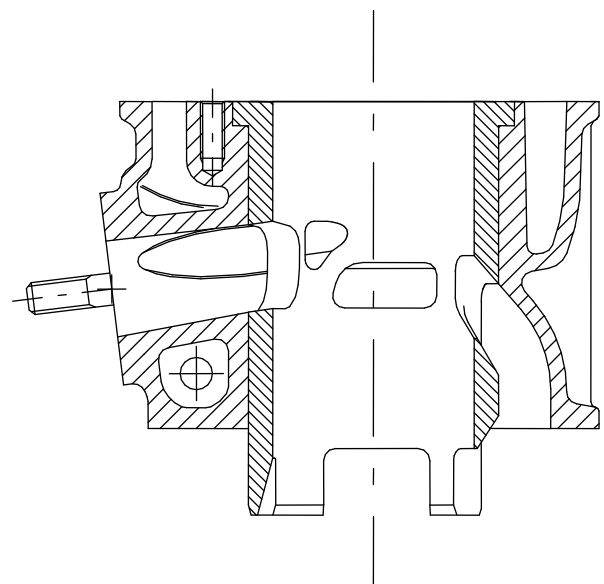
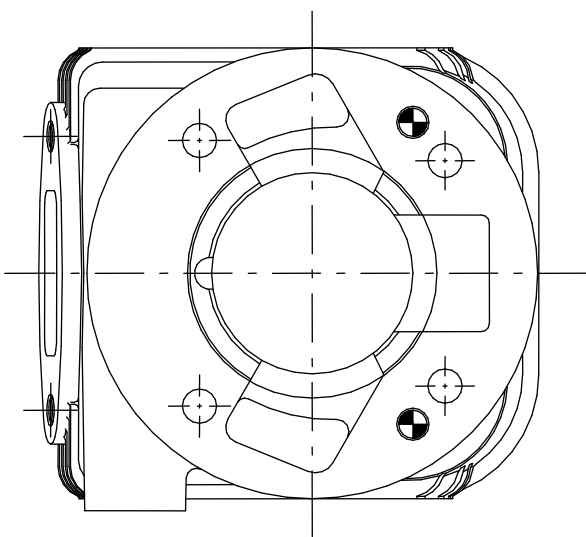
DESSIN DU PIED DU
CYLINDREDRAWING OF THE
CYLINDER BASEVUE EN SECTION DU
CYLINDRECYLINDER SECTION
VIEW

297 / M / 09

DESSIN DE LA CULASSE ET DE LA CHAMBRE DE COMBUSTION

DRAWING OF THE CYLINDER HEAD AND OF THE COMBUSTION CHAMBER

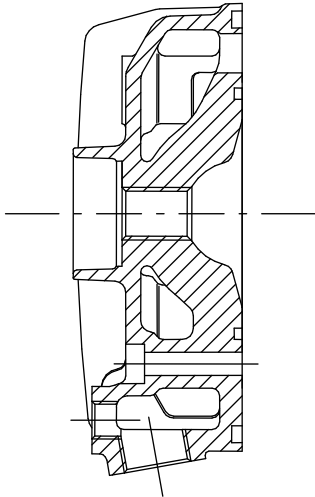
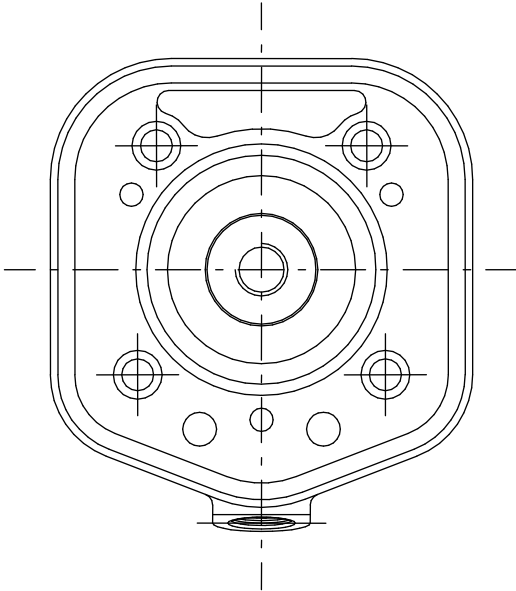

DESSIN DU VILEBREQUIN

DRAWING OF THE CRANKSHAFT

DESSIN INTÉRIEUR DU CARTER

DRAWING OF THE INSIDE OF SUMP

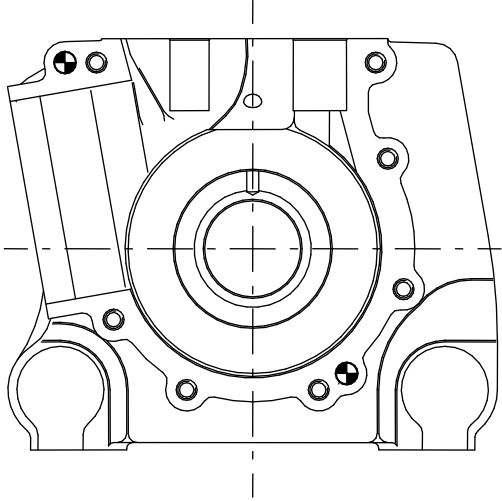
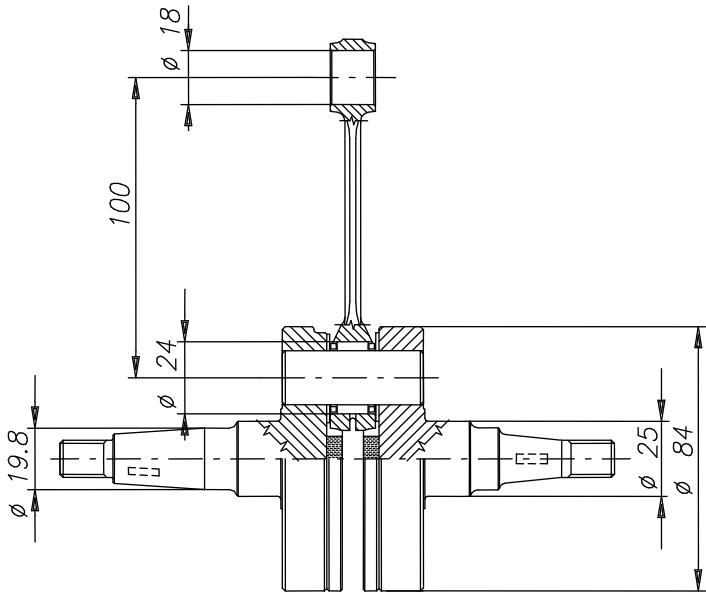

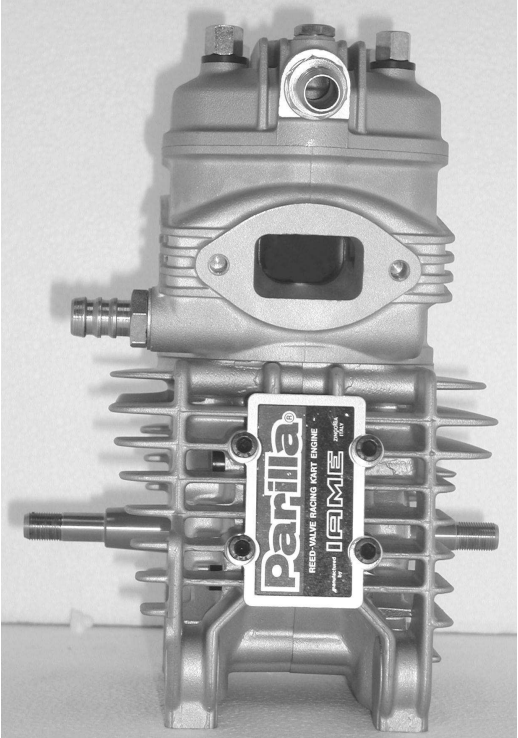
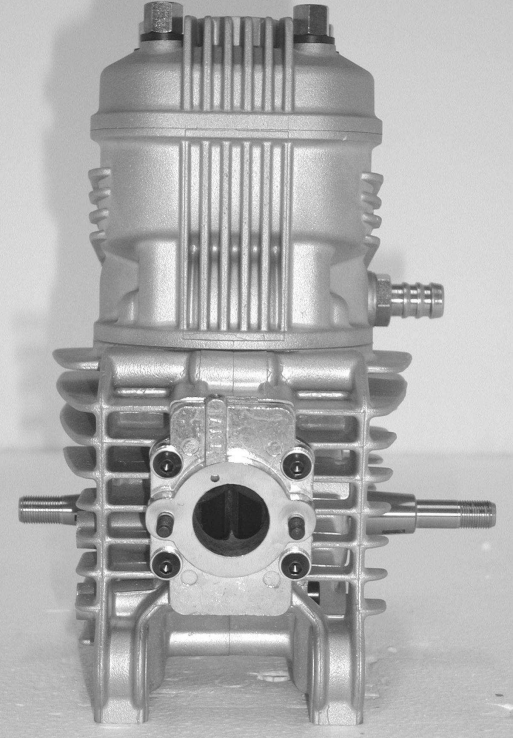
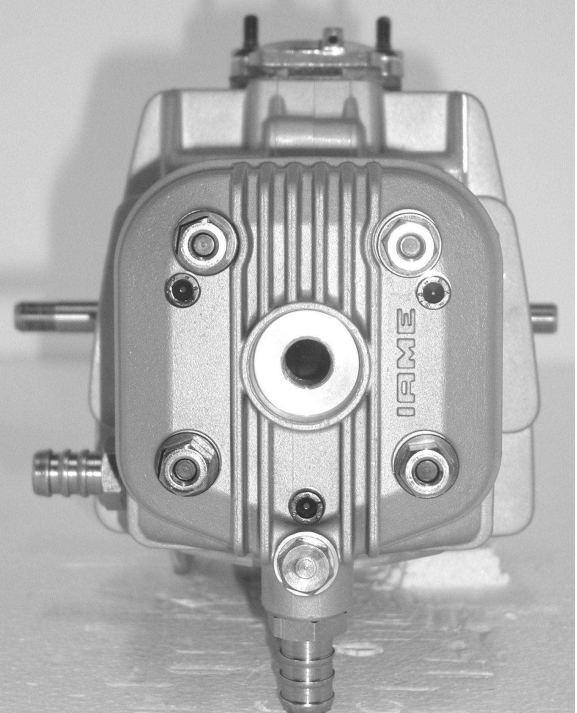
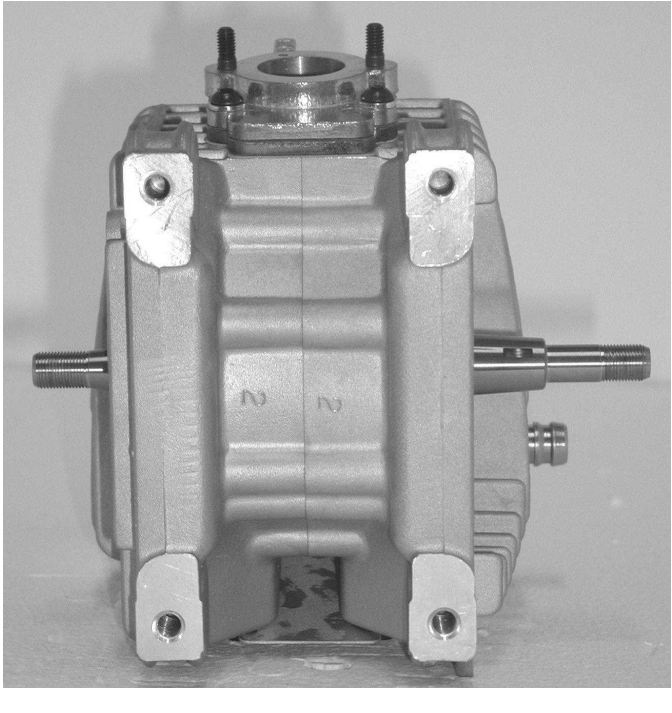
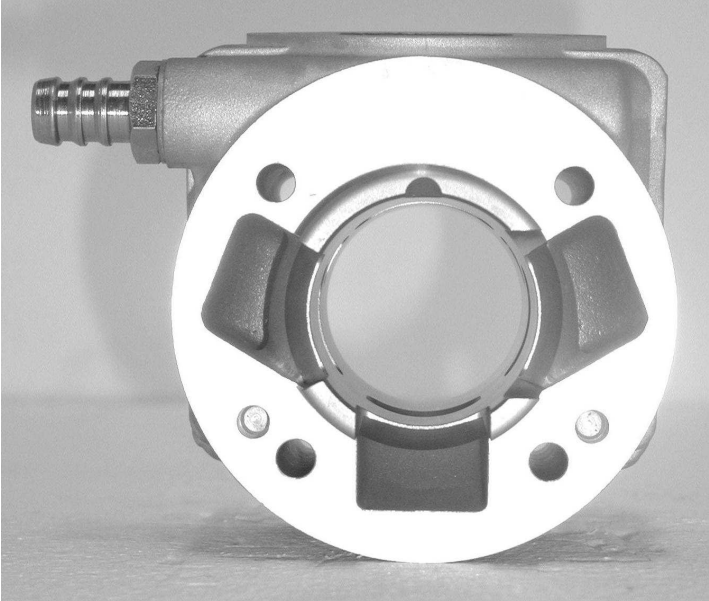

PHOTO DE L'ARRIÈRE DU MOTEUR	PHOTO OF THE BACK OF THE ENGINE	PHOTO DE L'AVANT DU MOTEUR	PHOTO OF THE FRONT OF THE ENGINE
			
PHOTO DU MOTEUR PARTIE SUPÉRIEURE	PHOTO OF THE ENGINE TAKEN FROM ABOVE	PHOTO DU MOTEUR PARTIE INFÉRIEURE	PHOTO OF THE ENGINE TAKEN FROM BELOW

PHOTO DU PIED DU CYLINDRE	<i>PHOTO OF THE BASE OF THE CYLINDER</i>	PHOTO DE LA CHAMBRE DE COMBUSTION	<i>PHOTO OF THE COMBUSTION CHAMBER</i>
			
PHOTO DU CARTER (CÔTÉ JOINT)	<i>PHOTO OF THE SUMP (GASKET FACE)</i>	PHOTO D'UNE PARTIE INTÉRIEURE DU CARTER	<i>PHOTO OF AN INTERNAL PART OF THE SUMP</i>
			

DESSIN DU SILENCIEUX ET DE SES
ÉLÉMENTSDRAWING OF THE SILENCER AND OF ITS
COMPONENTS

Épaisseur minimum de la paroi du pot-silencieux 0,8 mm / Minimum thickness of the wall of the exhaust silencer 0.8 mm.
Poids minimum de l'échappement 1.450 Kg / Minimum weight of the exhaust 1.450 Kg.

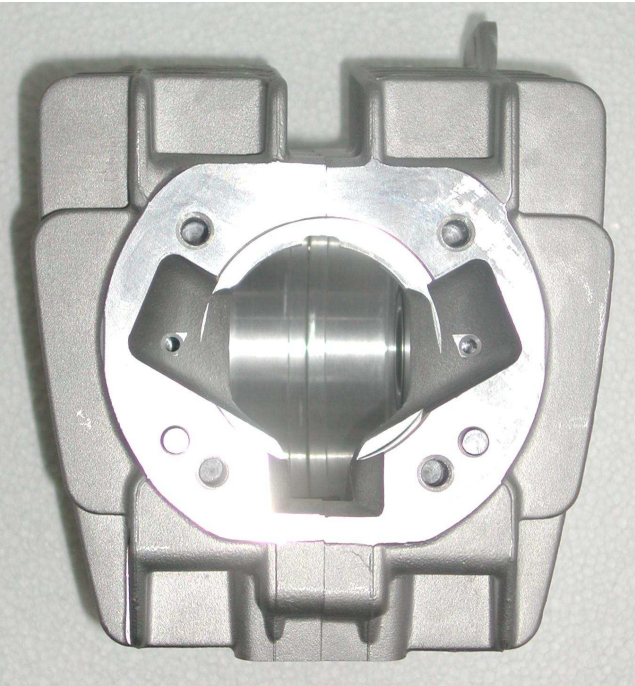
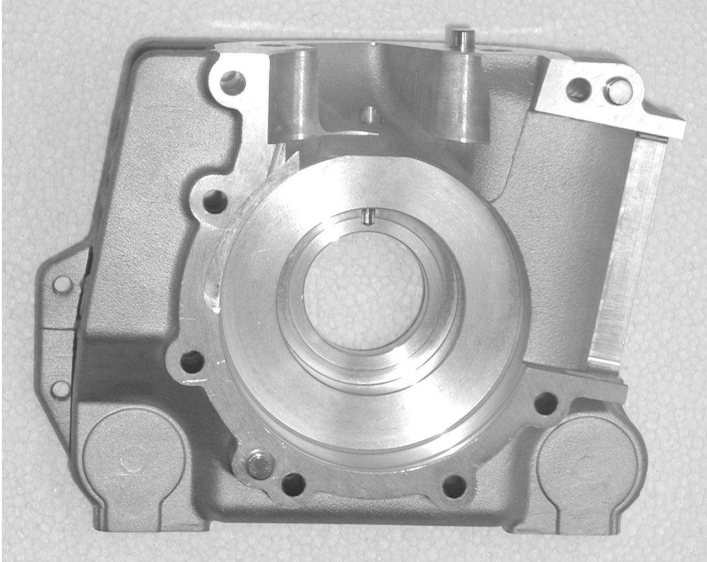
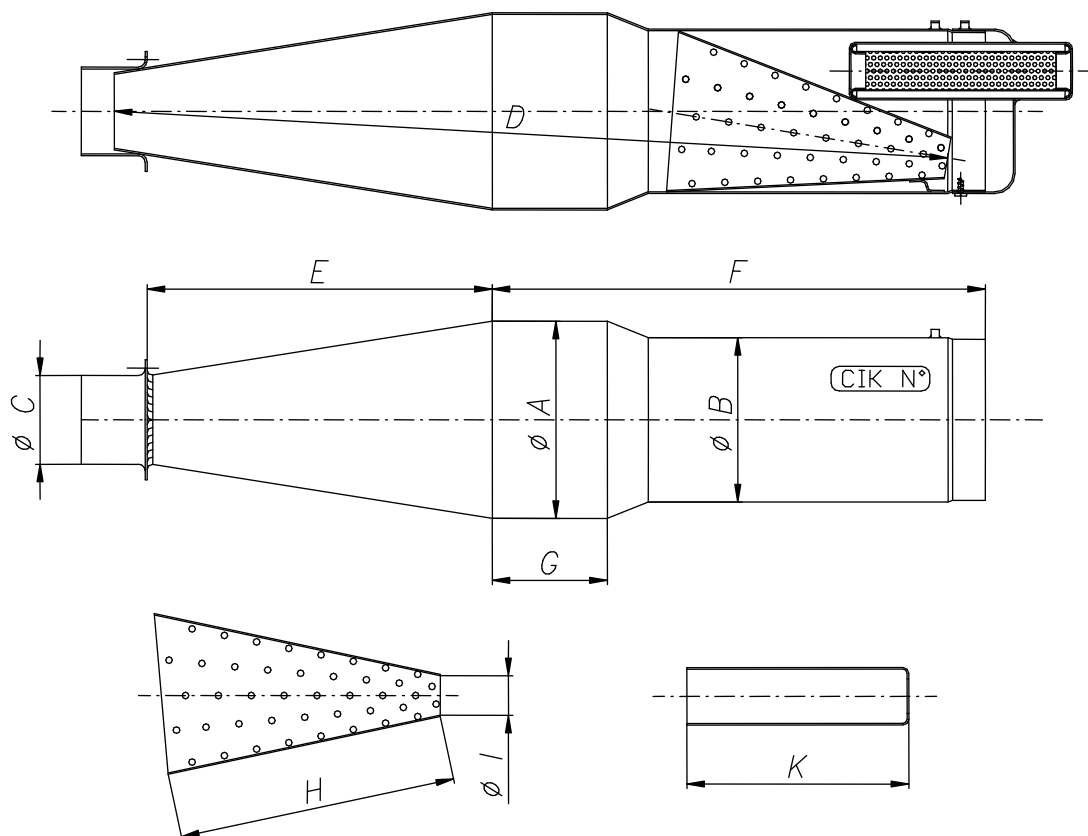

Les parties terminales du silencieux doivent présenter deux paires d'anneaux soudés (une en haut et une en bas), pour retenir le sceau en plomb fixé par l'Organisateur pour que le silencieux ne puisse pas être ouvert pendant la compétition.

The end parts of the silencer must have two soldered pairs of lugs (one pair at the top and one pair at the bottom) for the fixing of seals by the Organiser so that the silencer may be opened during the competition

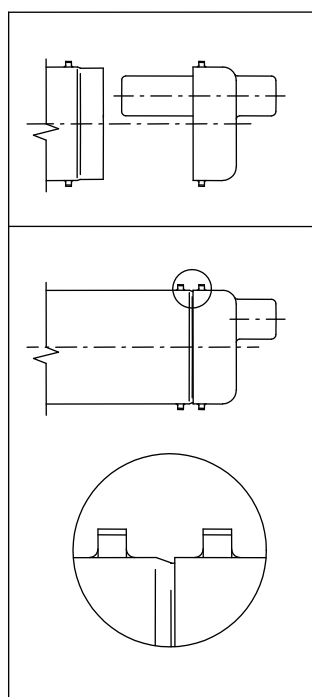

Cotes / Readings:

A: 110 Øext.F: 322 B: 100 Øext.G: 104 C: 54 Øext.H: 172 D: 485 I: 22 E: 172 K: 131

TOLÉRANCES

Cotes brutes / Rough dimensions
Jusque - up to 25mm → ±1mm
De à - from to 25-60mm → ±1,5mm
Plus que - more than 60mm → ±3mm